



Table of Contents

Section	Page
Notes to Designer/User	1-2
Map of Typical Roof Conditions	3
Fastener Placement	4
Fastener Selection	5
Box-Rib, Reversed Box Rib, HR-36, Reversed HR-36, Mini-V-Beam and Super Span Details	
Ridge/Hip Flashing	6
Valley Flashing	7
Eave Flashings	8
Gutter Flashings	9
Gable Flashings	10
Peak Flashing	11
Sidewall Flashings	12
Endwall Flashing	13
Panel End Lap	14
Window/Door Trim	15
Drip Edge/Wall Step, Panel Top	16
Inside Corner	17
Outside Corner	18
Nu-Wave Corrugated & U-Panel Details	
Ridge/Hip Flashing	19
Valley Flashing	20
Eave Flashing	21
Gutter Flashing	22
Gable Flashing	23
Peak Flashing	24
Sidewall Flashing	25
Endwall Flashing	26
Base Trim Detail	27
“C” Trim Detail	28
Inside Corner	29
Outside Corner	30

Notes to the Designer/User

The details contained in this packet are intended to be a design aid and do not depict all situations. Modifications are the responsibility of the designer/user and should take into account climate conditions such as wind and snow, governing code requirements, and the actual usage and maintenance of the structure. Where possible, roof panel side laps and flashings should be lapped away from prevailing winds. Certain flashings should be supported if it is likely that a ladder will be used against them or if foot traffic is anticipated. Check with AEP Span any time you intend to specify a prefinished flashing in a gauge different than the panels. It is good practice to specify that all flashings be of the same material as the panels (gauge, color, finish) to ensure long-term durability. Field-painted flashings rarely equal the durability and color fastness of factory baked-on paint systems. Where possible, we have hemmed the edges of flashings to strengthen them and to minimize the exposure of cut edges.

Framing- The details contained in this guide are shown with panels attached to spaced support members.

Slope requirements- It is suggested that all panels in this booklet be used on slopes of 1:12 or greater, except Nu-Wave Corrugated® and U-Panel which have a 3:12 minimum slope requirement.

Condensation, Insulation & Ventilation- It is the designer's responsibility to determine the need and composition of condensation control materials including insulation and vapor retarders, as well as ventilation requirements. Metal roofing is susceptible to condensation and its control should be carefully considered.

Valleys- Valley dimensions must be the proper width to account for slope, snow, ice, and rain conditions. If valleys are not kept free of debris, water can back up and intrusion may occur under the panels.

Snow Design- If possible, valleys, gutters, roof elevation changes and penetrations should be minimized or eliminated in snow areas. Roof penetrations should be located as close to the ridge or peak of the roof as possible to minimize accumulations of ice and snow.

Curved Roofs- Box Rib, HR-36, Super Span, U-Panel, and Nu-Wave Corrugated® panels are suitable for installation over curved surfaces. Box Rib, HR-36, U-Panel and Super Span panels are factory crimp curved. Nu-Wave Corrugated panels are factory smooth curved. Mini-V-Beam panels are not available curved.

Oil-Canning- Flat metal surfaces will display waviness commonly referred to as "oil-canning". This is caused by steel mill tolerances, variations in the substrate and roofing underlayments. Oil canning is a characteristic, not a defect, of panels manufactured from light-gauge metal. Coils are factory "corrective-levelled" prior to rollforming to minimize oil canning. Oil canning is not a cause for panel rejection. Additional information is available upon request.

References- The Sheet Metal and Air Conditioning Contractors' National Association Inc. (SMACNA) manual is an excellent reference for sheet metal contractors. Its guidelines for underlayments, gutter and downspout size requirements, and expansion/contraction of metals and flashings joints should be followed.

Technical Assistance- Call your AEP Span Sales or Technical Representative for additional information on any of these subjects.

Notes to the Designer/User *continued*

Definitions-

- Sealant: Gunnable-grade single-component polyurethane
- Mastic: Butyl mastic tape or butyl rubber
- Hem: A 180° bend that is closed (or as closed as the formability of the metal will allow) to provide a uniform, attractive edge. High ten-



sile strength (Grade 80) steel must be formed with a “teardrop hem” as shown to avoid cracking the steel at the bend. Lower tensile steels can be flattened close.

- Hook: (also called an “open hem”) A 180° bend on a piece of sheet metal that is left open to allow inser-
- 
- tion of another piece of

sheet metal. For example, the hook shown is used to hold the trim piece to a cleat below the trim.

Each flashing part in this guide has been assigned a part number. Each part number contains one or two letters followed by one or two numbers, for example: (EW6). These part numbers have been provided for you to make ordering these flashing parts quick and easy.

Map of Typical Roof Conditions

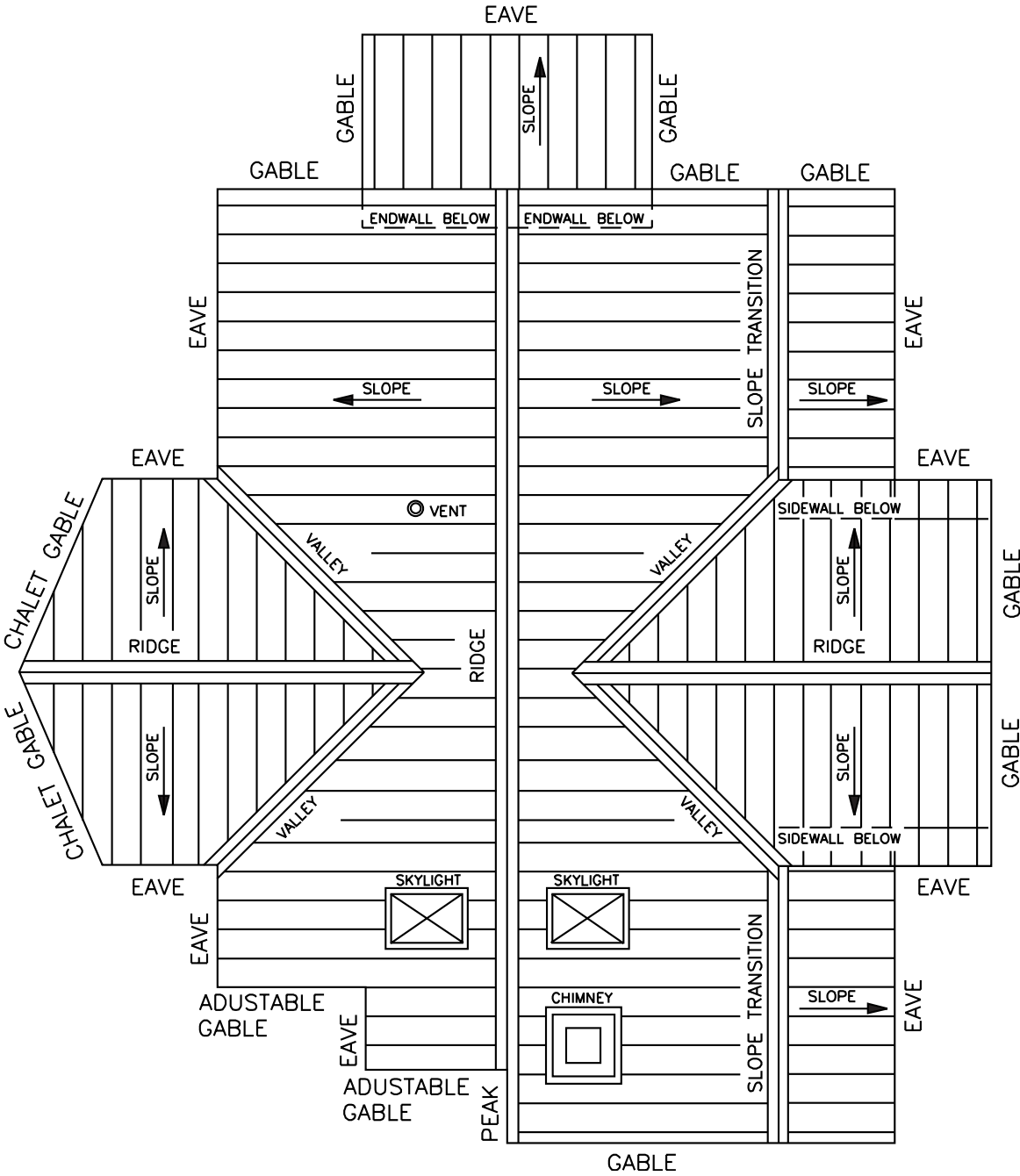

For suggestions on how to trim flashings in the different areas, please refer to the following pages:

Flashing	Page(s)
Eave	.8, 21
Endwall	.13, 26
Gable	.10, 23
Gutter	.9, 22
Panel Endlap	.14

Flashing	Page(s)
Peak	.11, 24
Ridge/Hip	.6, 19
Sidewall	.12, 25
Valley	.7, 20

Fastener Placement

Prevailing Weather → ← Sheeting Direction

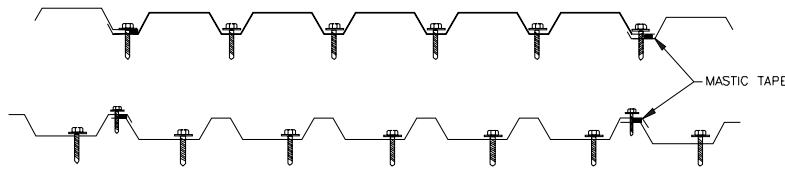

Box Rib
(36" Coverage)
Wall application only

Reverse Box Rib
(36" Coverage)
Roof or Wall application

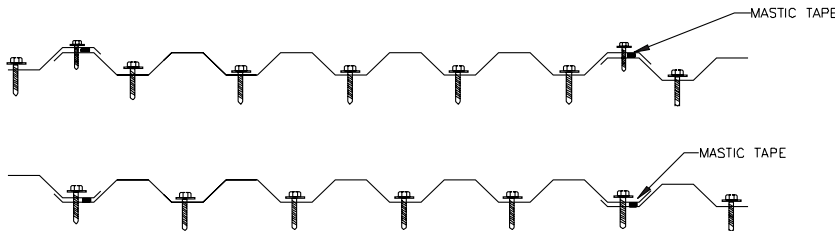

HR-36
(36" Coverage)
Roof or Wall application

Reversed HR-36
Wall application only

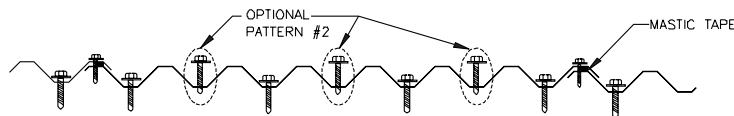

Mini-V-Beam
(32" Coverage)
Roof or Wall application

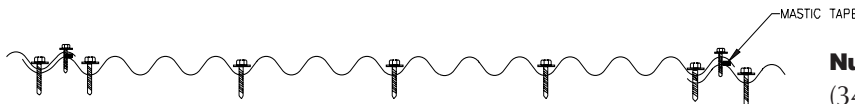

Nu-Wave Corrugated
(34 2/3" coverage) Wall application only



Nu-Wave Corrugated
(32" Coverage) Roof Application

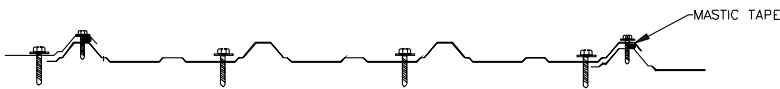

Super Span
(36" Coverage)

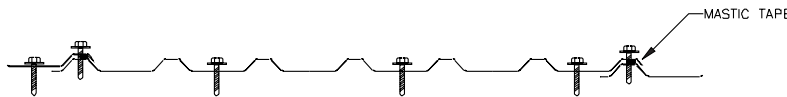













U-Panel
(36" Coverage)

Note: Lap panels away from prevailing weather. Use only those accessories specifically designed for use with this product. Use only galvanized or Zincolume®-coated fasteners. Isolate roofing and flashings from contact with dis-

similar metals. Fastener selection will vary based upon substrate. The use of butyl mastic tape along the sidelaps, as shown above, is always recommended for roof panels.

Fastener Selection

Fastener #	Description	Use
	 #9 x 1", 1 1/2", 2", 2 1/2", 3" Wood Screw 1/4" Hex Head	Panel to Dimensional Lumber
	 #14 x 1", 2" Wood Screw 5/16" Hex Head	Panel to Plywood Minimum 1/2" thick, structural grade
	 #12 x 3/4" Stitch Screw 1/4" Hex Head (compatible with #10 wood screw)	Trim and side lap attachments
	 #14 x 7/8" Lap Self Driller 5/16" Hex Head (compatible with #14 wood screw)	Trim and side lap attachments. Attach panels to 18, 20, 22 gauge supports.
	 STST-42 Stainless Steel Rivet 1/8 x 1/8	Trim-to-trim or trim-to-panel attachments
	 #12 x 1", 1 1/2", 2", 1 1/2" Self Driller 5/16" Hex Head	Panel to purlin attachments

Notes:

- The table above shows the metal buildings panel fasteners provided by AEP Span. Refer to the panel flashing details and fastener placement pages of this manual for specific usage.
- Panel attachment screws must be long enough to fully penetrate through the roof decking, or penetrate solid lumber at least one inch.
- All screws must be coated to provide protection against corrosion.
- Exposed fasteners should have sealing washers and be the same color as the parts they attach.
- Roofing nails will also be required, but not furnished by AEP Span. They are typically used to temporarily hold a flashing in place that needs to be installed prior to panels.
- Screws must be properly driven to ensure proper seal and holding strength. Do not underdrive or overdrive the screws. Recommended drill speed is 2000 rpm. Use of a depth-sensing nosepiece will aid in properly driving screws.

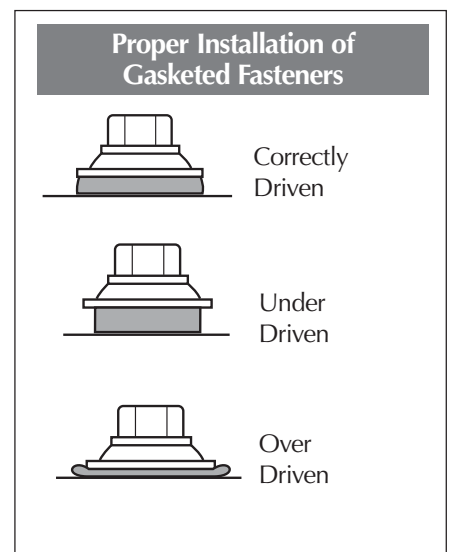

Ridge/Hip Flashing

Box Rib, HR-36, and Super Span

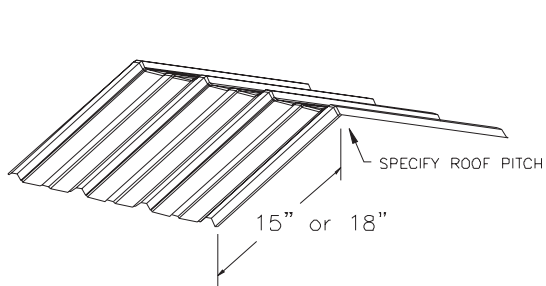

Formed Ridge (R6)
Super Span

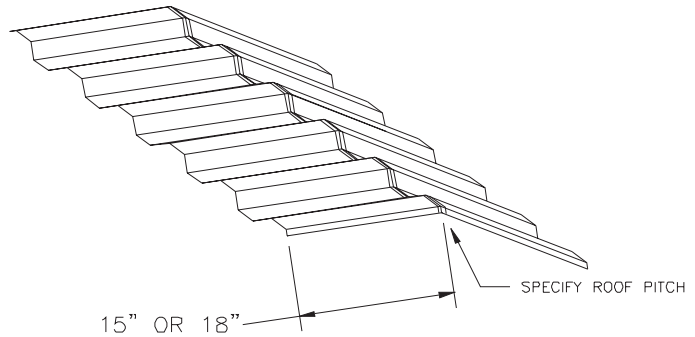

Formed Ridge (R11)
HR-36 and Box Rib

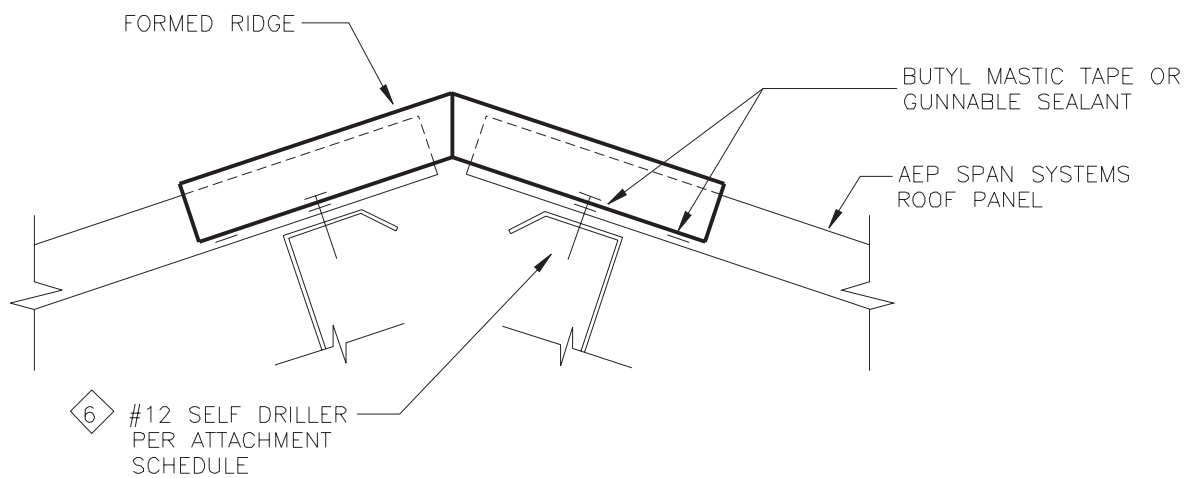

Note:

Maximum pitch with formed ridge 3:12.

Valley Flashing

Box Rib, HR-36, Mini-V-Beam and Super Span

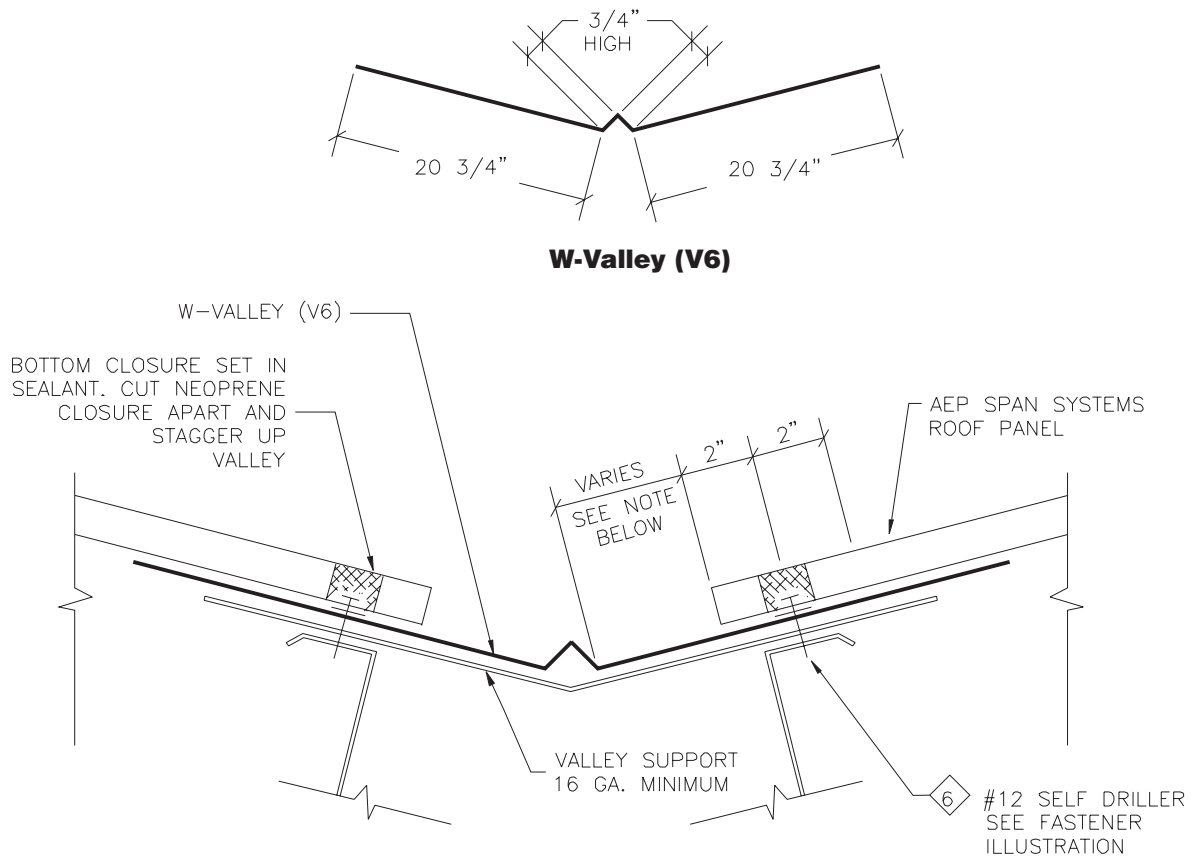

Note:

- Valley dimensions must be the proper width to account for slope, snow, ice and heavy rain conditions. An underlayment such as a rubberized cold-applied membrane is recommended extending a minimum of 3'-0" up from the center of the valley on each side.
- Special ordered beveled closures available for a specific pitch/slope.

Eave Flashing

Box Rib, HR-36, Mini-V-Beam and Super Span

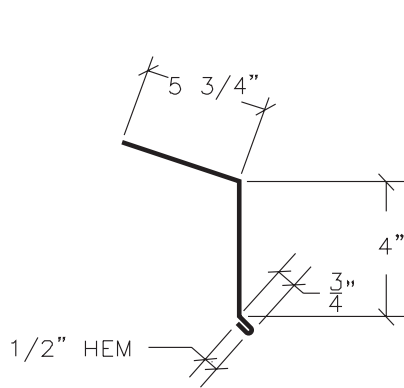

Eave (E6)

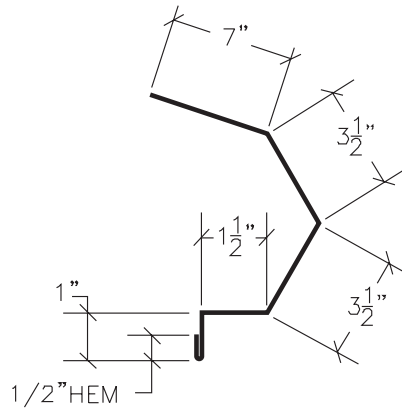

Sculptured Eave (E7)
optional

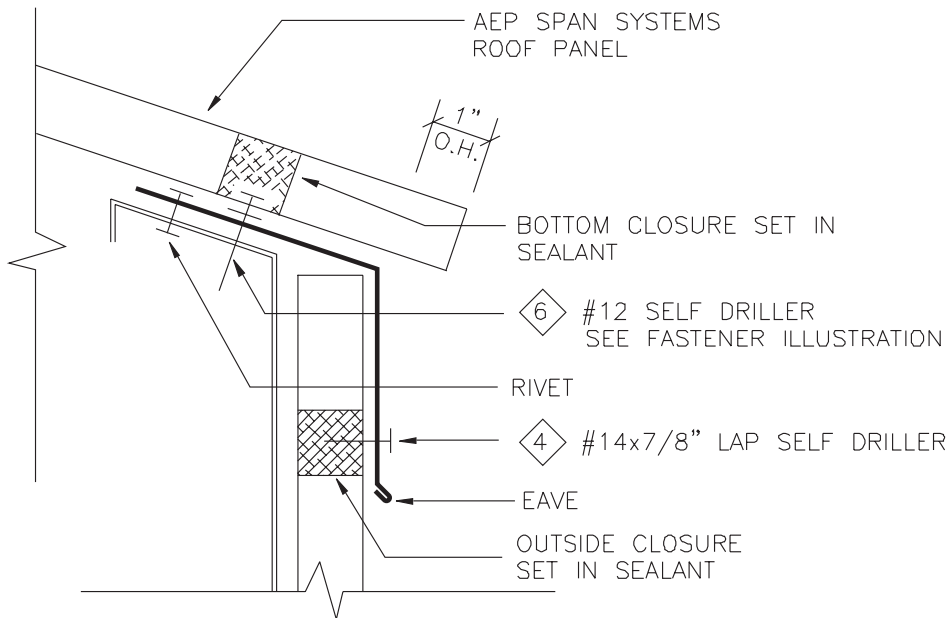

Gutter Flashings

Box Rib, HR-36, Mini-V-Beam and Super Span

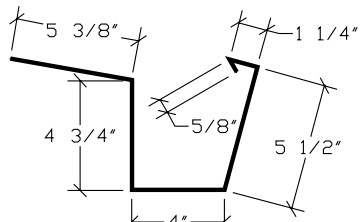

Box Gutter (GU6)
pre-hung

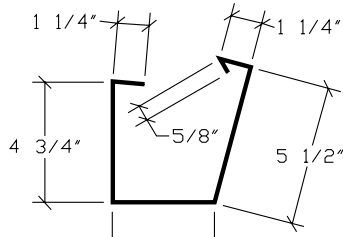

Box Gutter (GU8)
post-hung

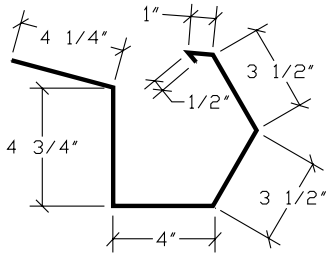

Sculptured Gutter (GU7)
pre-hung

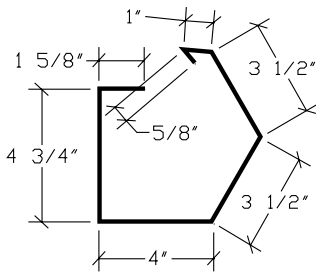

Sculptured Gutter (GU9)
post-hung

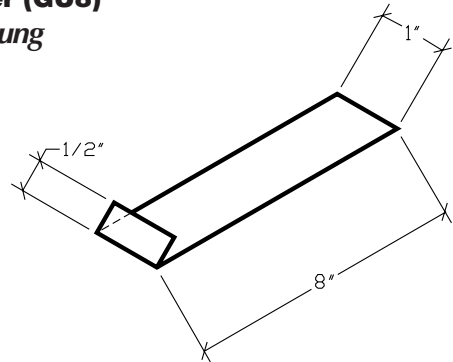

Gutter Strap (GS6)

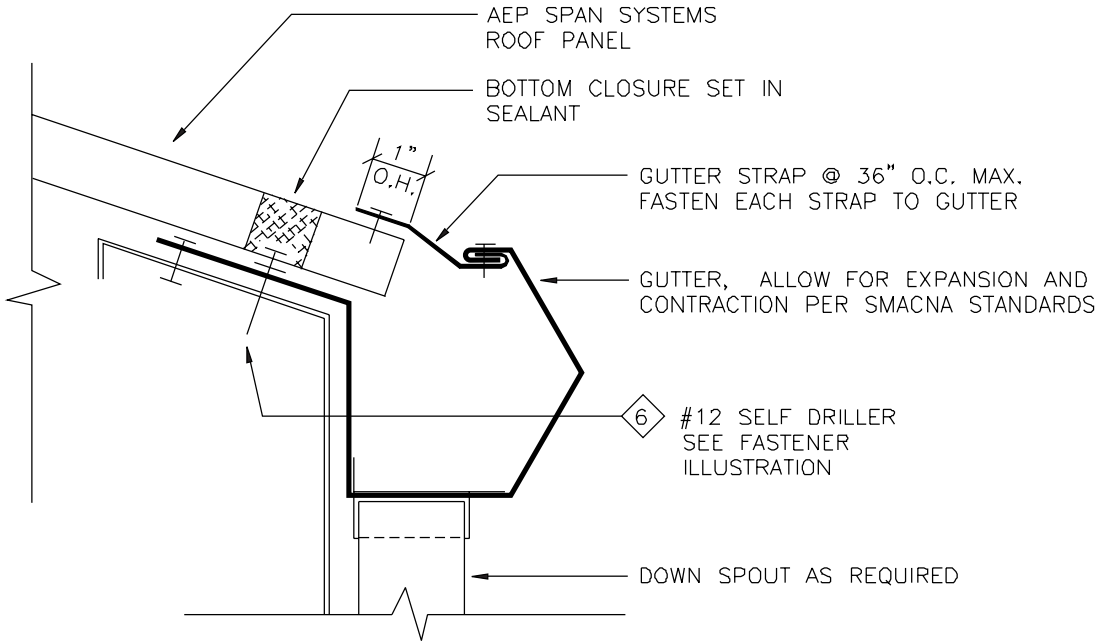

Gable Flashings

Box Rib, HR-36, Mini-V-Beam and Super Span

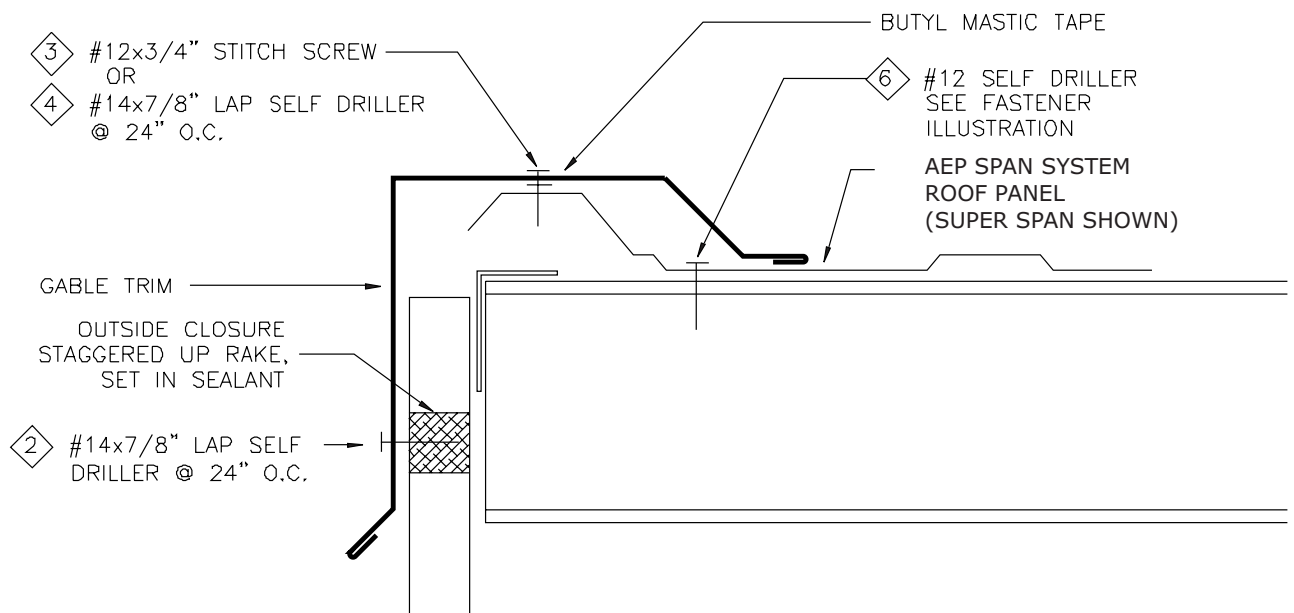
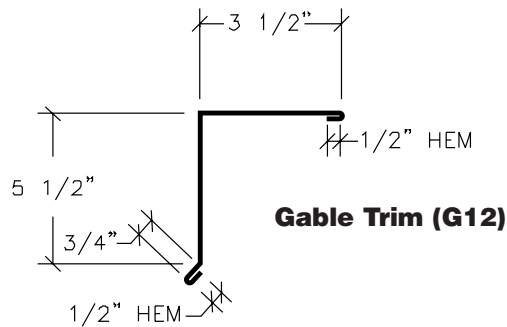
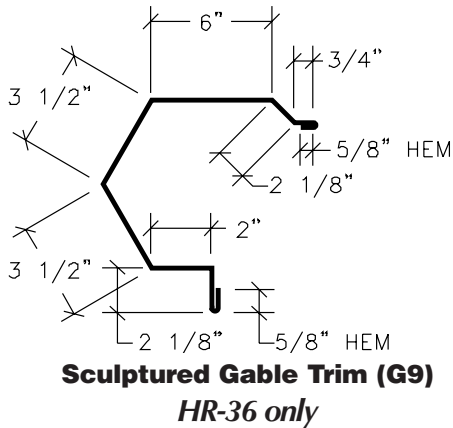
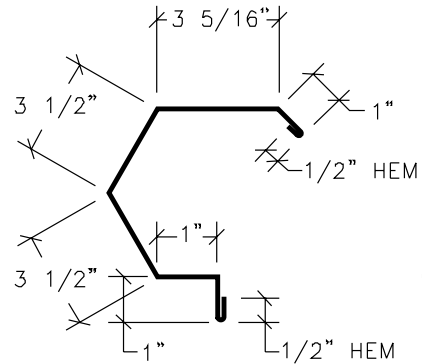
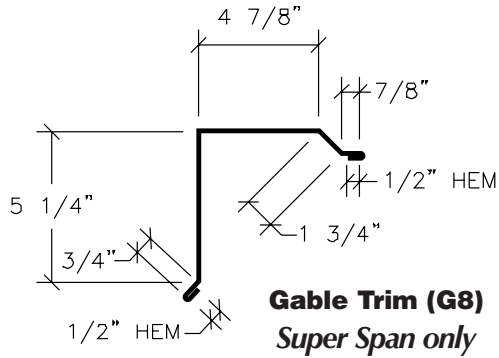

Peak Flashings

Box Rib, HR-36, Mini-V-Beam and Super Span

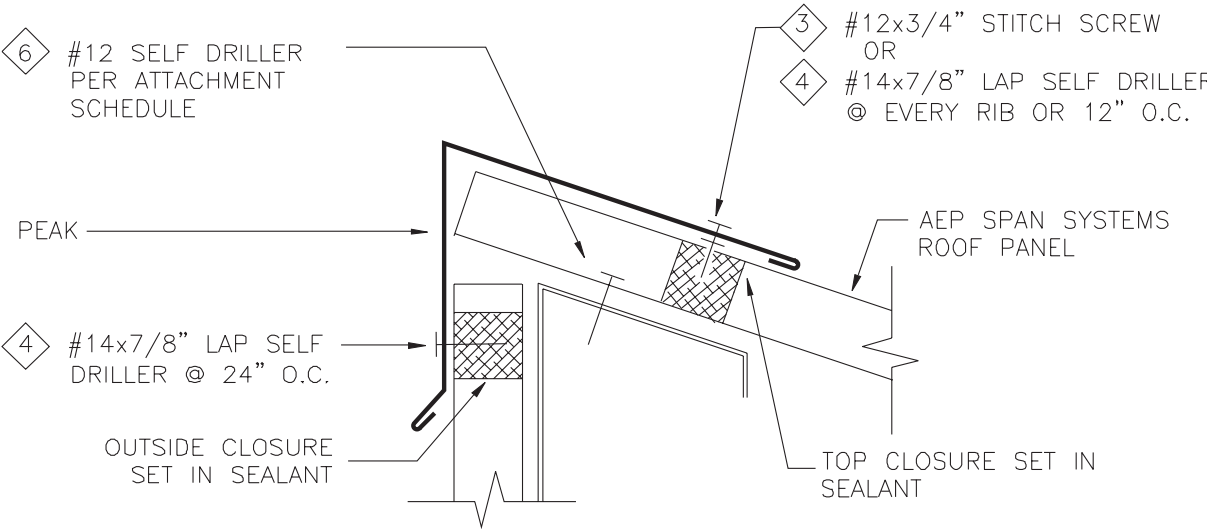
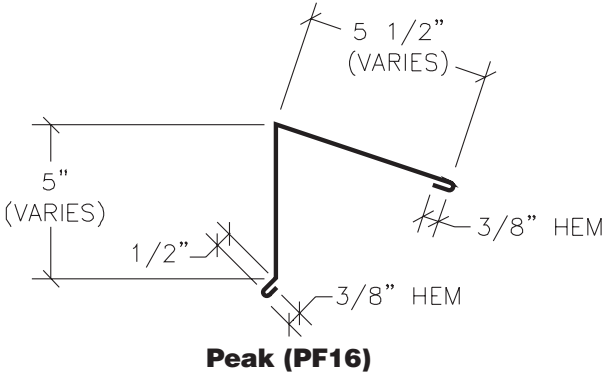

Sidewall Flashings

Box Rib, HR-36, Mini-V-Beam and Super Span

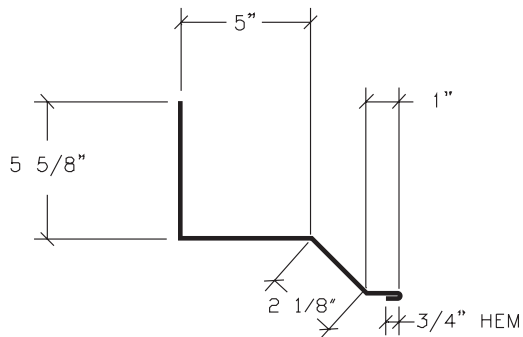

Sidewall (SW7)
Super Span only

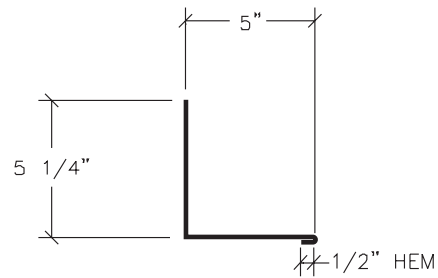

Sidewall (SW8)

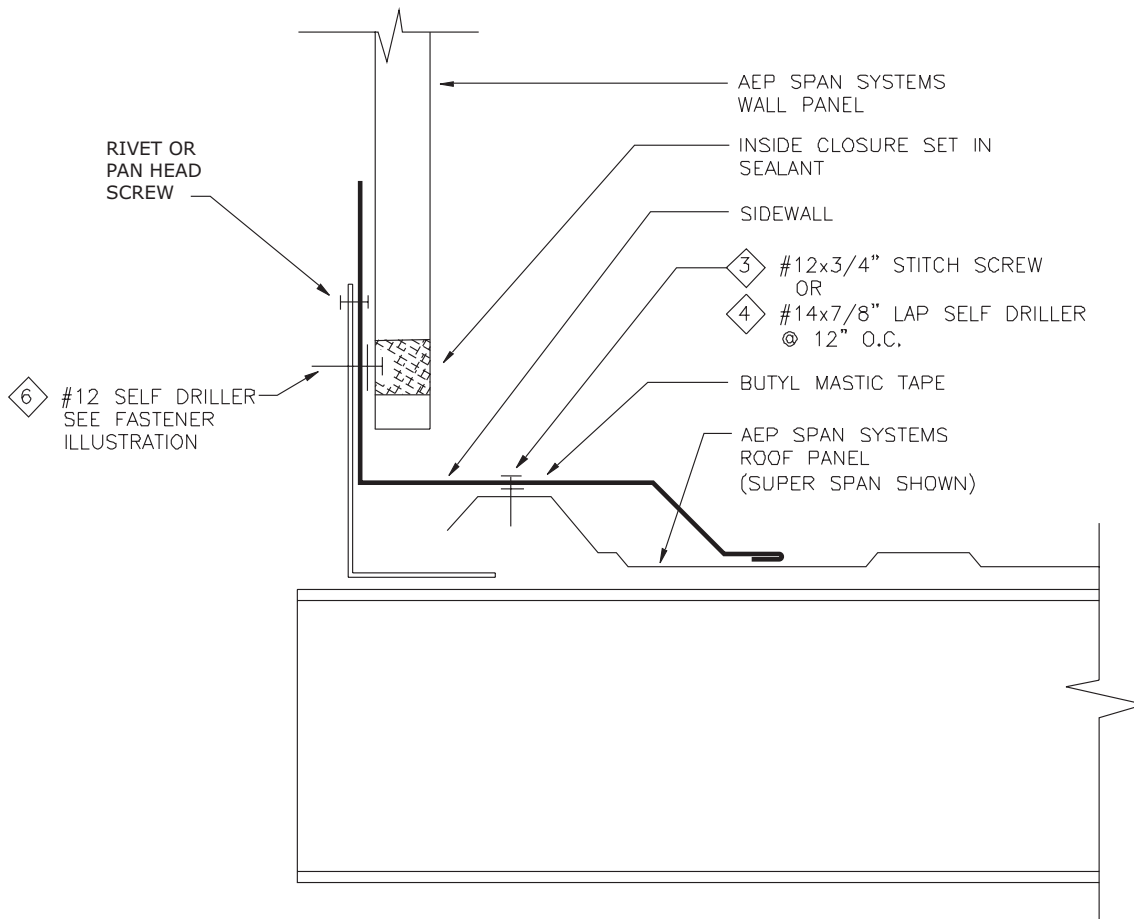

Endwall Flashing

Box Rib, HR-36, Mini-V-Beam and Super Span

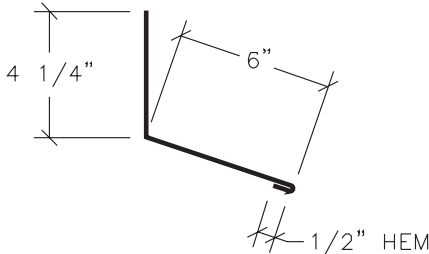

Endwall (EW6)

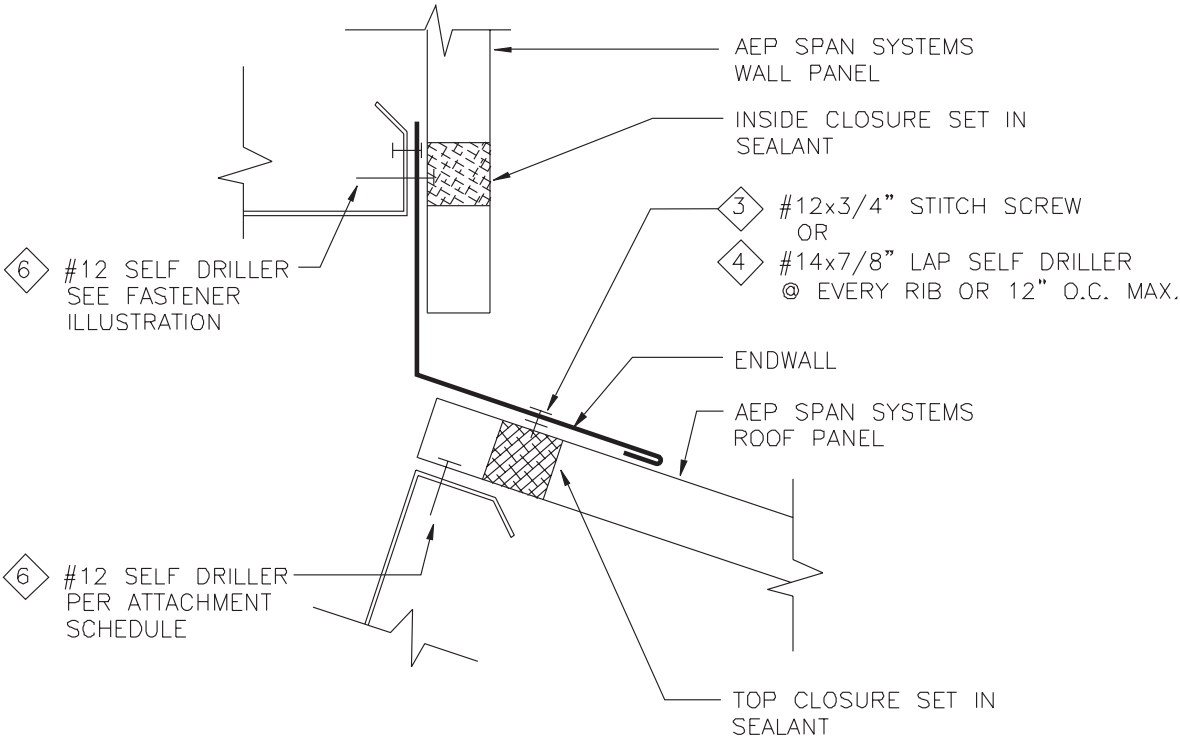

Panel Endlap

Box Rib, HR-36, Mini-V-Beam and Super Span

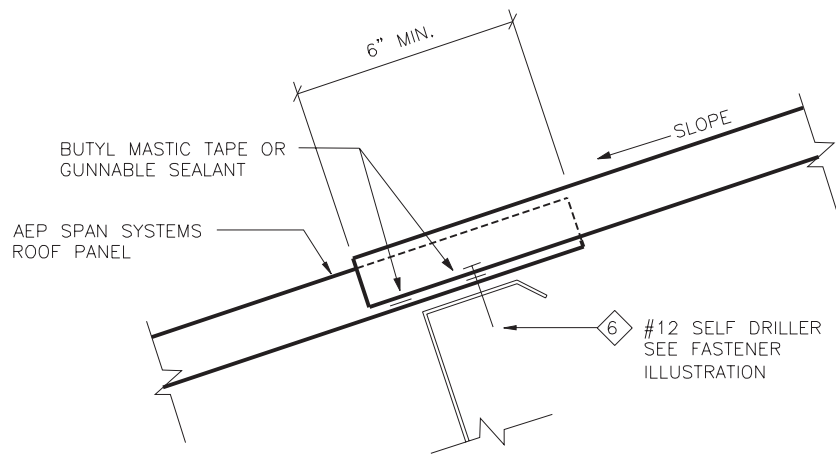

Wall Details
Window/Door Trim

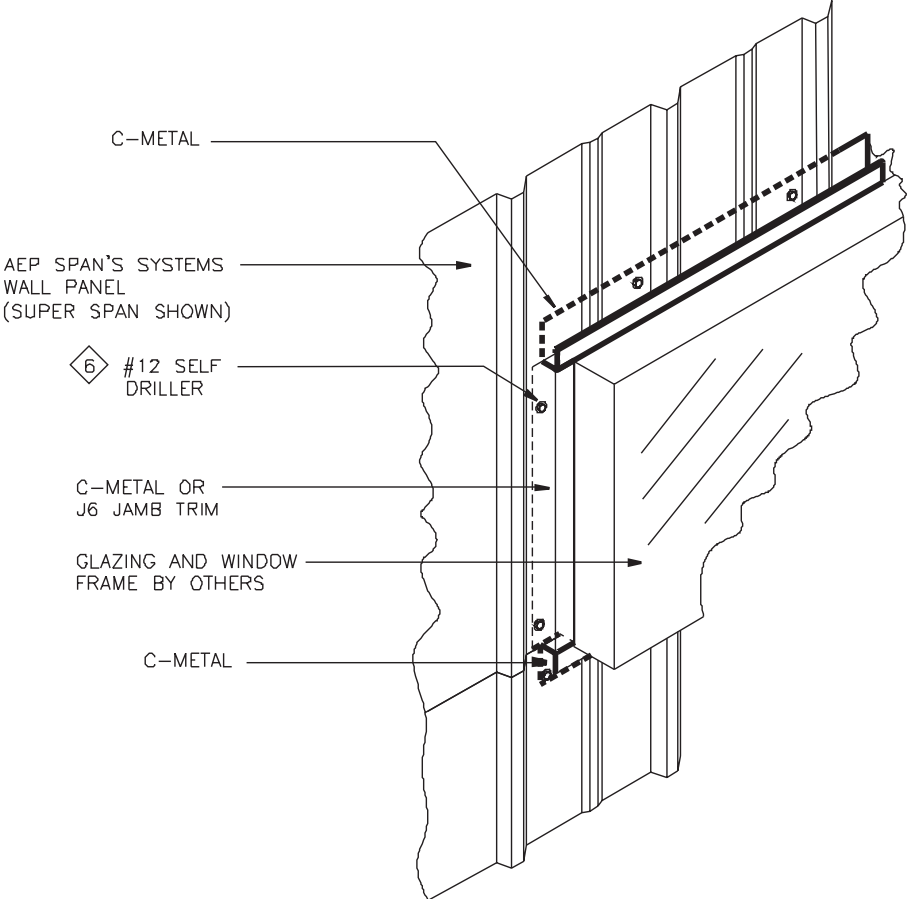
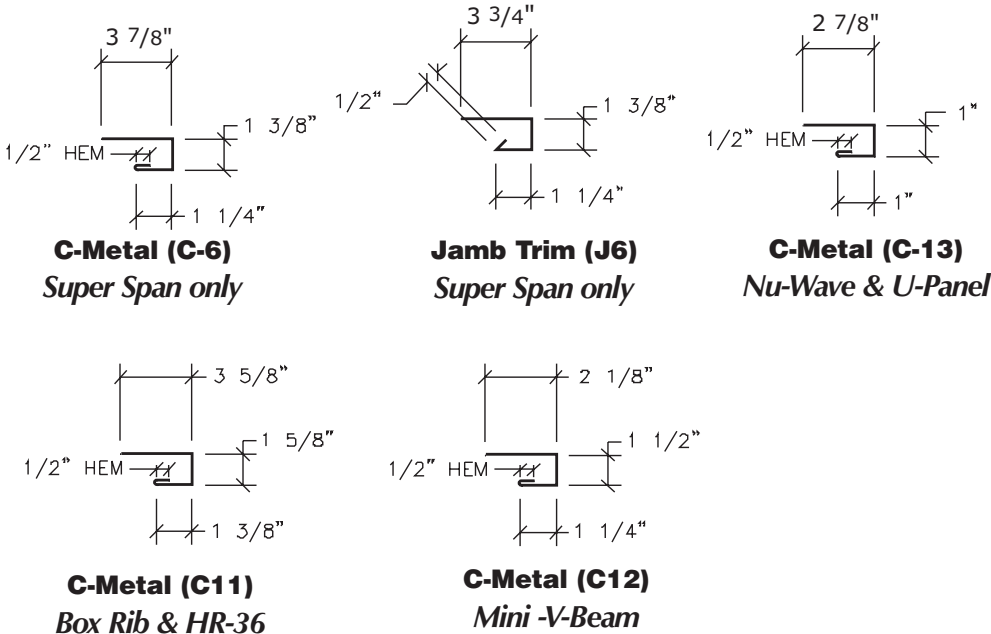

Wall Details • Drip Edge, Wall Step, Panel Top

Box Rib, HR-36, Mini-V-Beam and Super Span

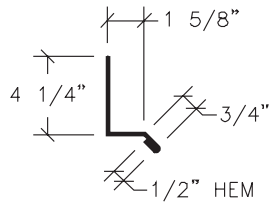

Drip Edge (B6)

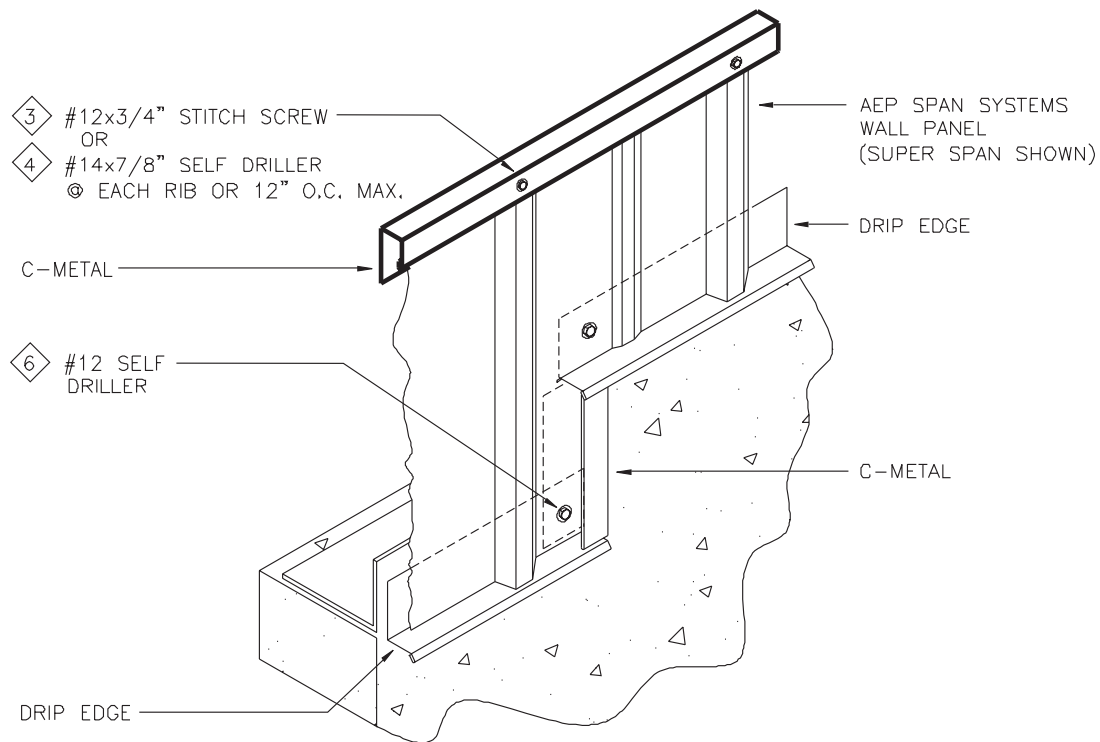

Wall Details • Inside Corner

Box Rib, HR-36, Mini-V-Beam and Super Span

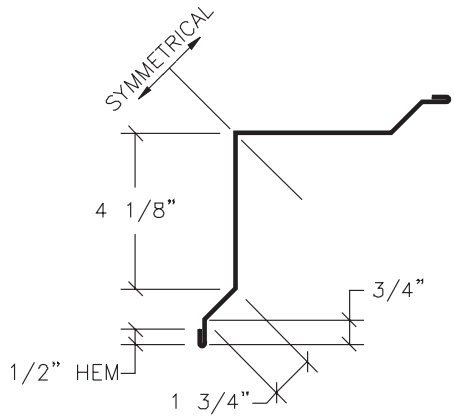

Inside Corner (IC7)

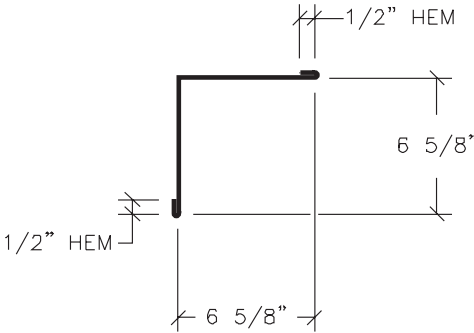

Inside Corner (IC 11)

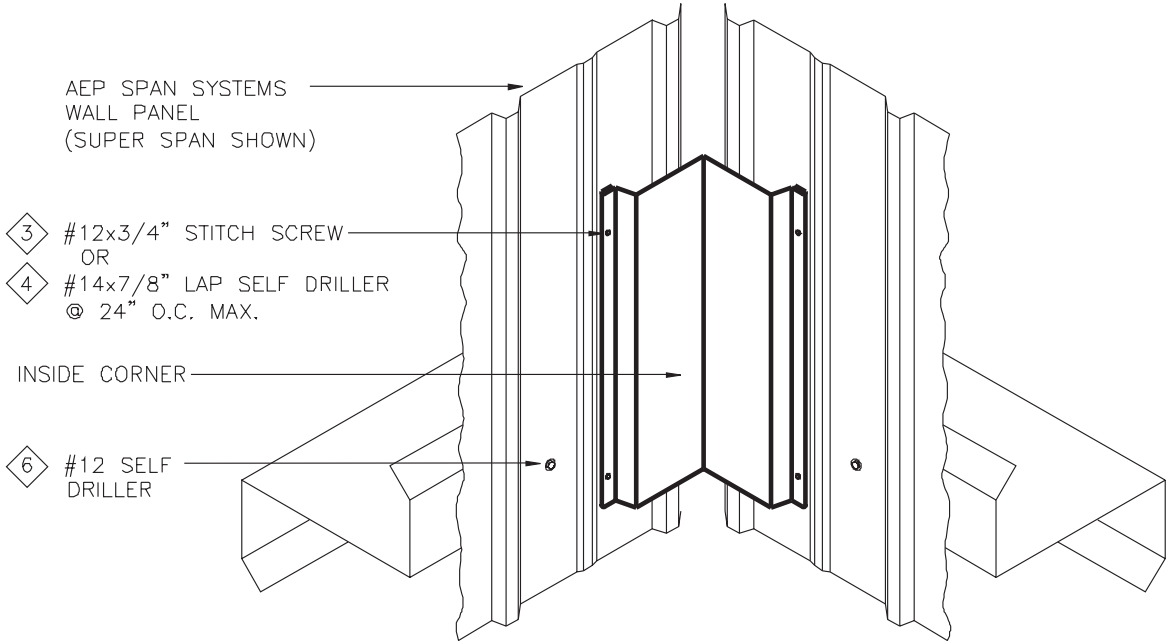

Wall Details • Outside Corner

Box Rib, HR-36, Mini-V-Beam and Super Span

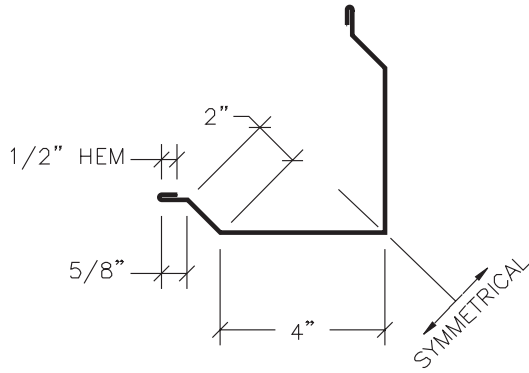

Outside Corner (OC7)
Super Span only

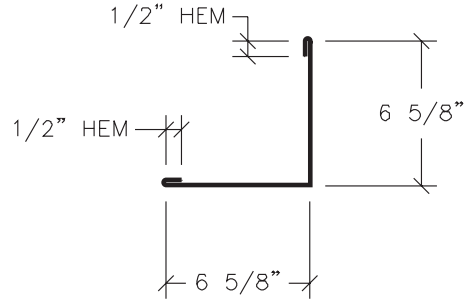

Outside Corner (OC11)

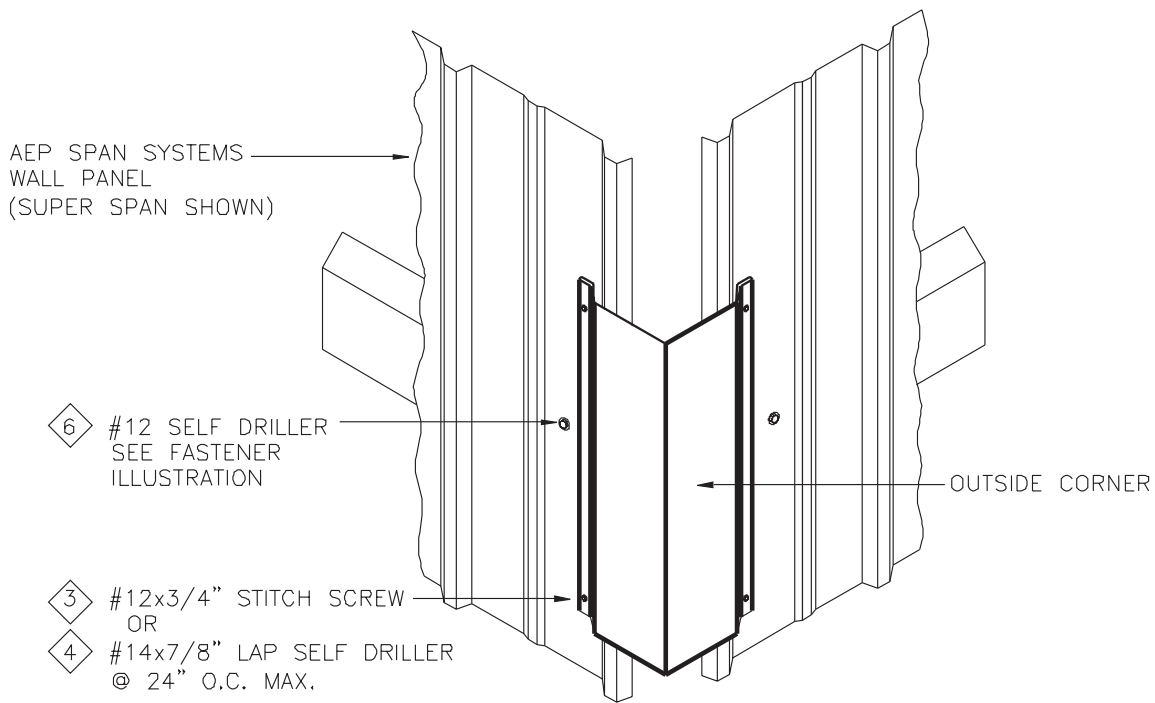

Ridge/Hip Flashing

NuWave Corrugated & U-Panel

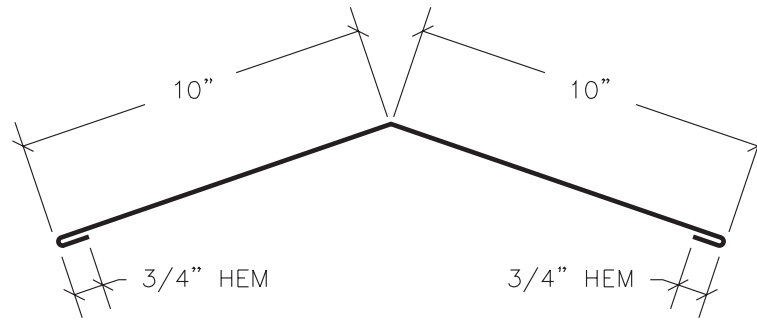

Ridge/Hip (R8)

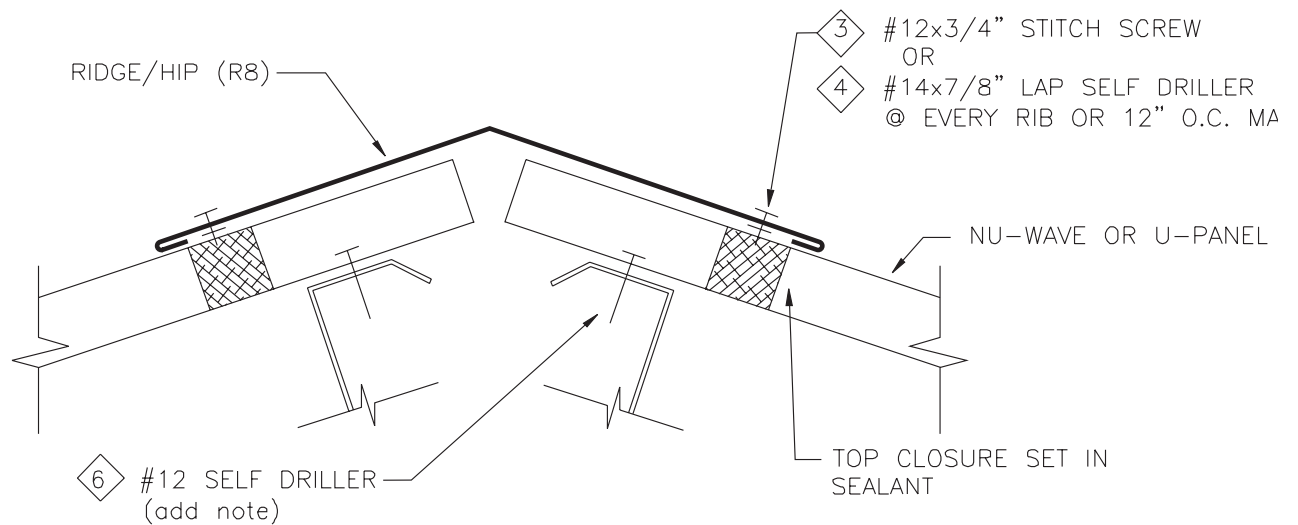

Note:

- Fasteners (except under ridge cap) should be located on tops of corrugations.
- Special ordered beveled closures available for a specific pitch/slope.

Valley Flashing

NuWave Corrugated & U-Panel

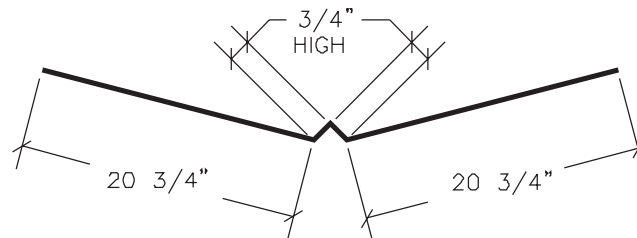

W-Valley (V6)

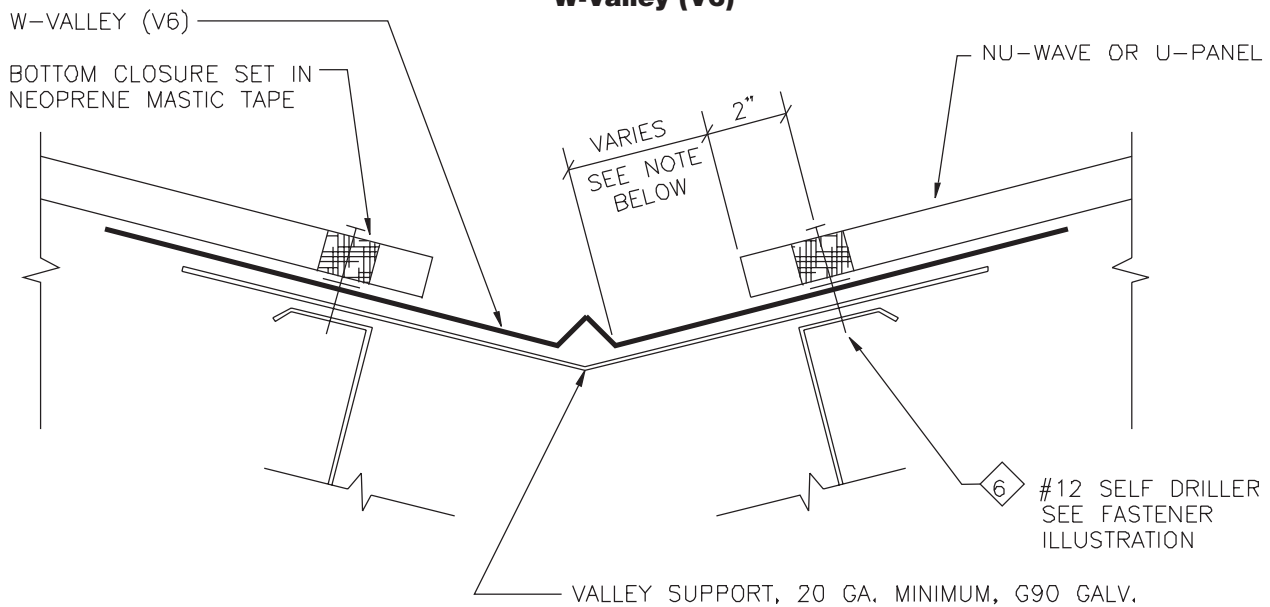

Note:

- Valley dimensions must be the proper width to account for slope, snow, ice and heavy rain conditions. An underlayment such as a rubberized cold-applied membrane is recommended extending a minimum of 3'-0" up from the center of the valley on each side.
- Special ordered beveled closures available for a specific pitch/slope.

Eave Flashing

NuWave Corrugated & U-Panel

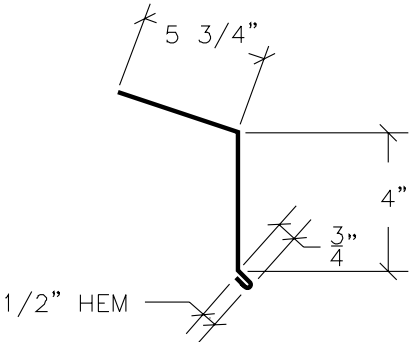

Eave (E6)

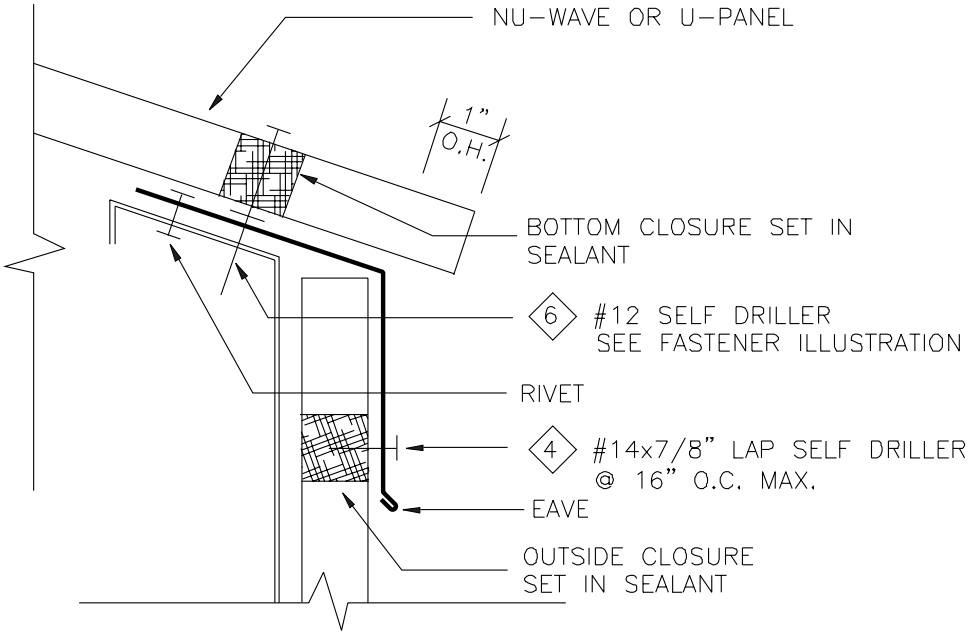

Gutter Flashing

NuWave Corrugated & U-Panel

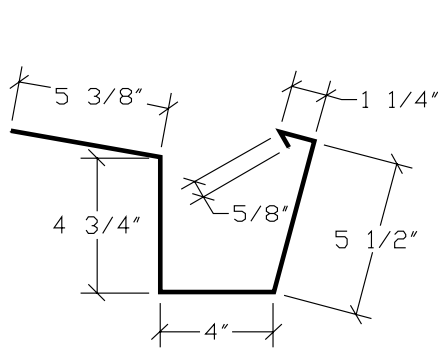

Box Gutter (GU6)
pre-hung

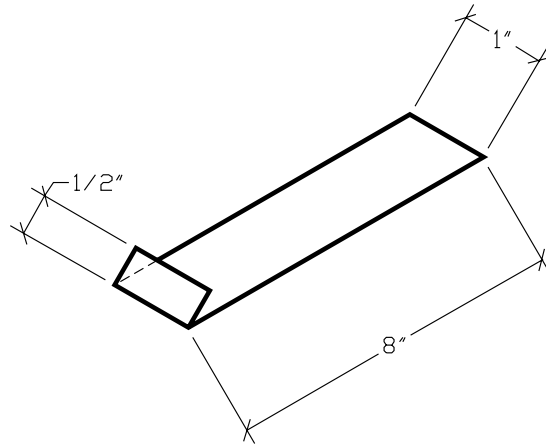

Gutter Strap (GS6)

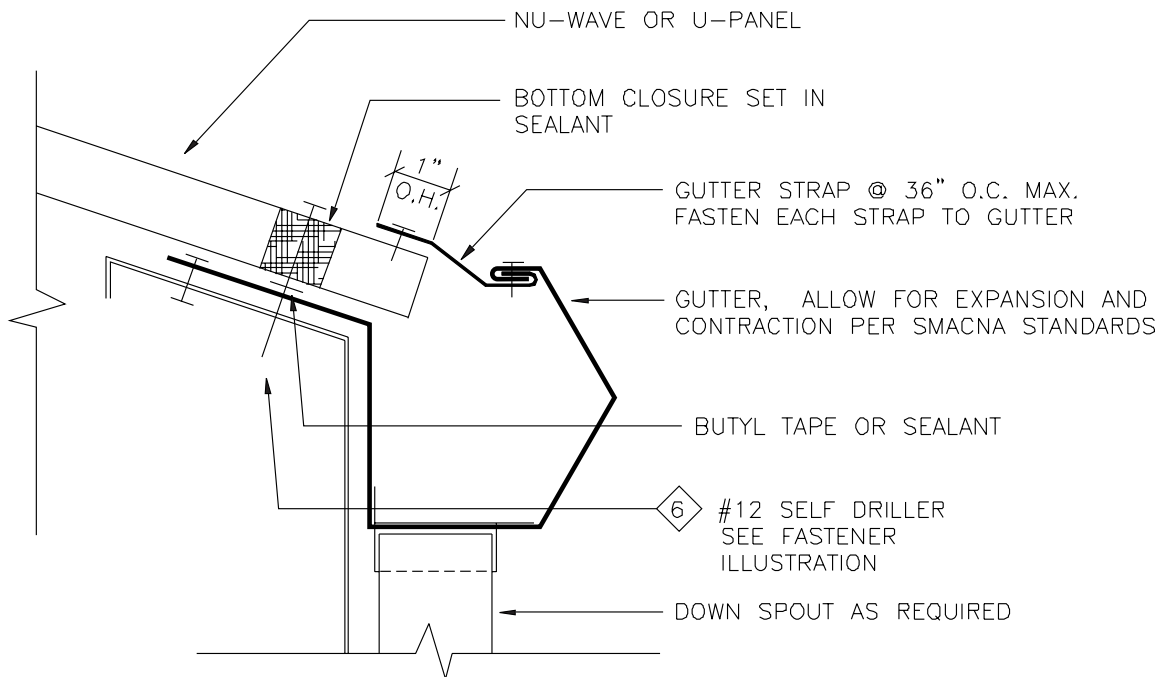

Gable Flashing

NuWave Corrugated & U-Panel

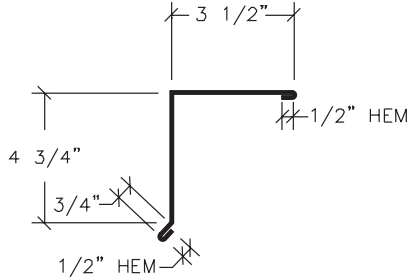

Gable Trim (G16)

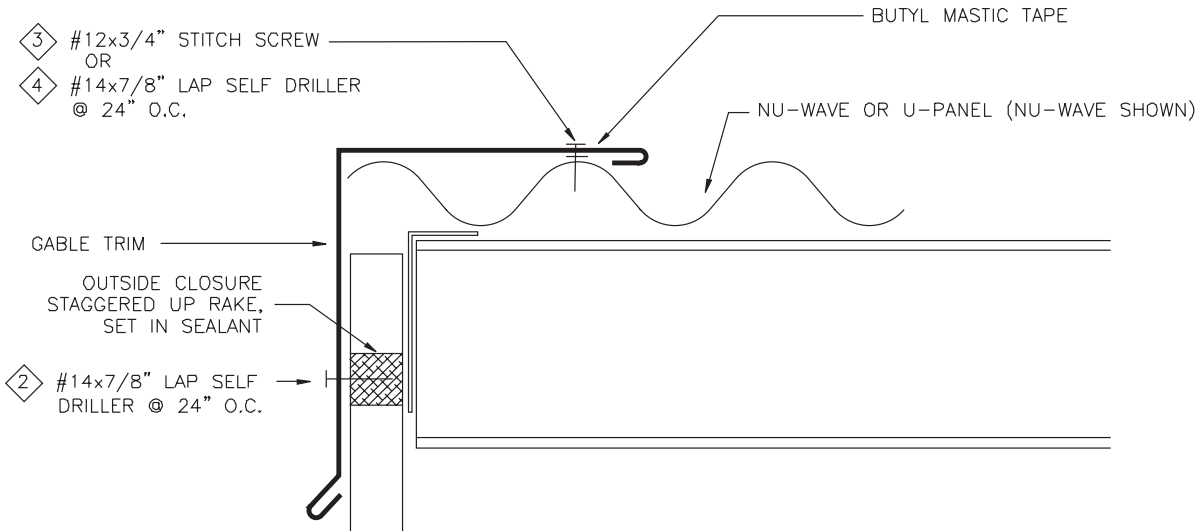

Peak Flashing

NuWave Corrugated & U-Panel

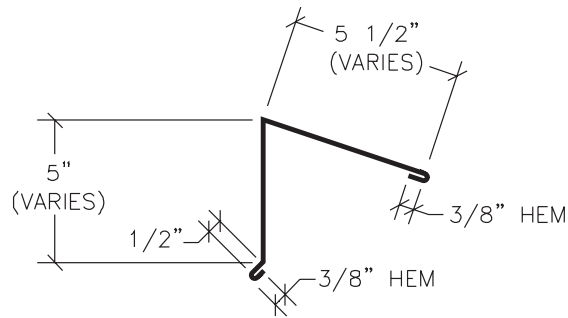

Peak (PF16)

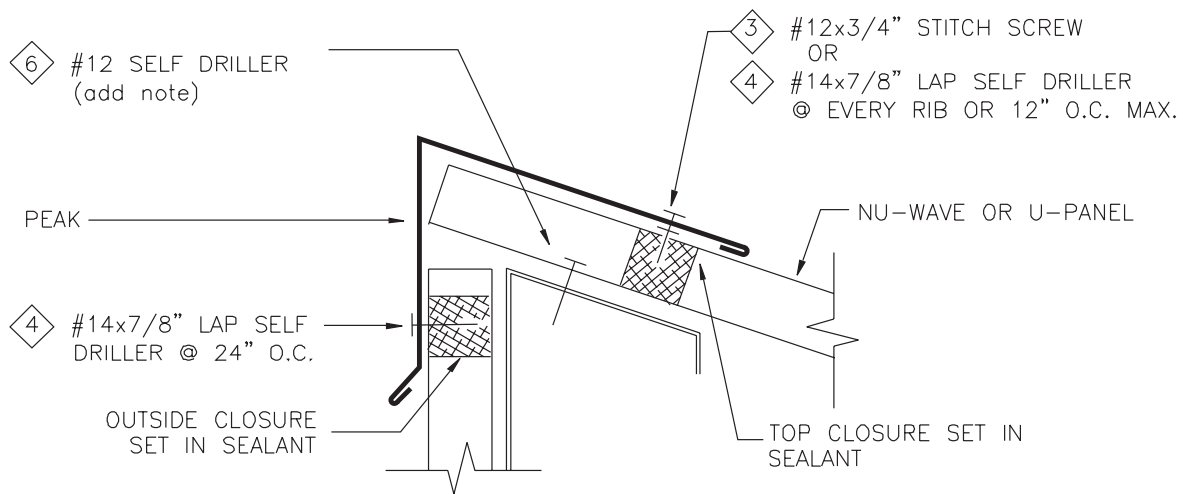

Sidewall Flashing

NuWave Corrugated & U-Panel

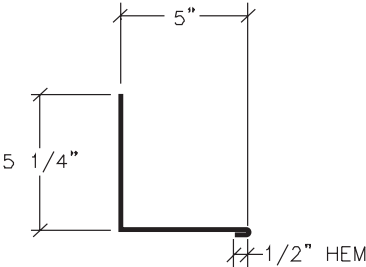

Sidewall (SW8)

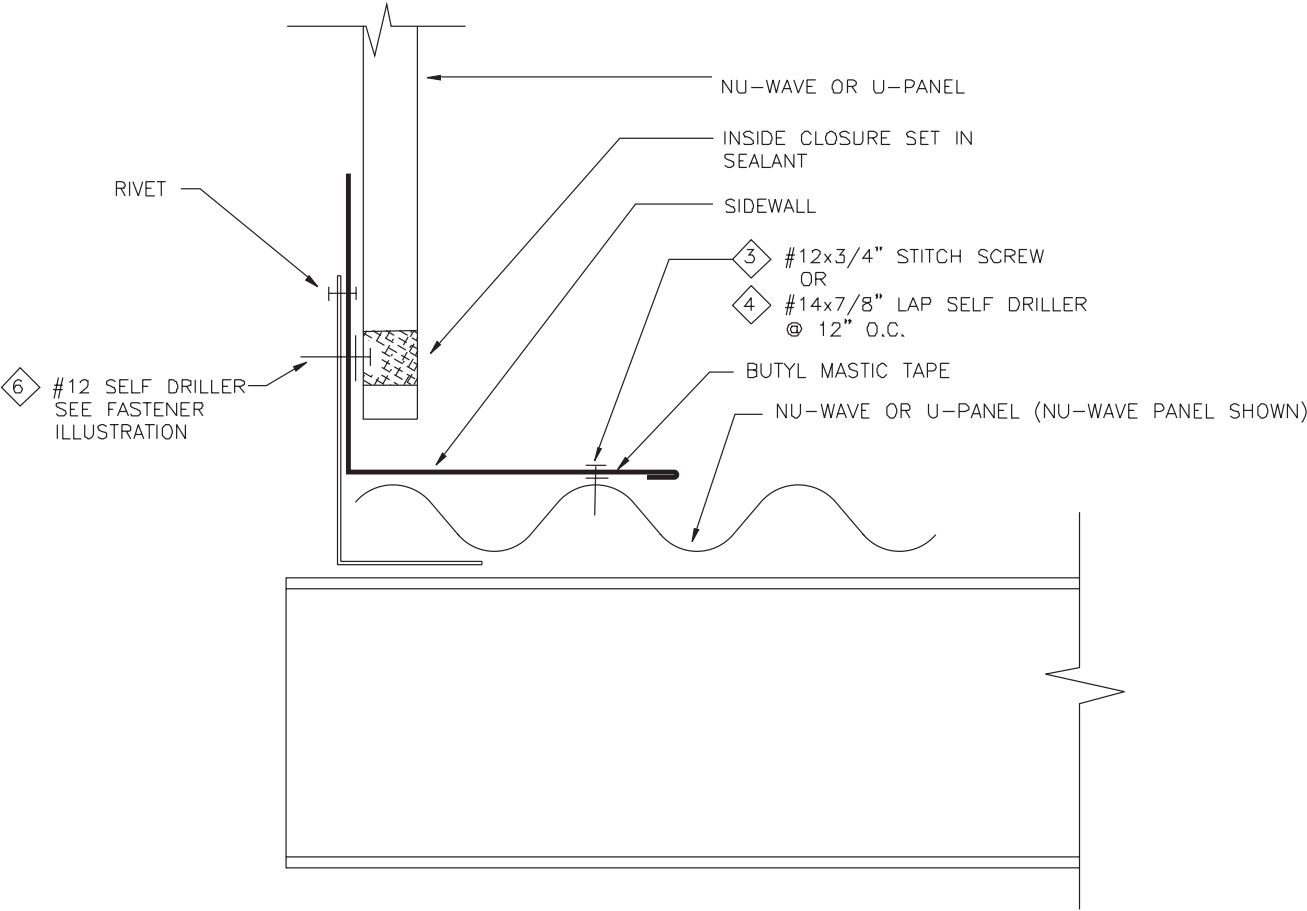

Endwall Flashing

NuWave Corrugated & U-Panel

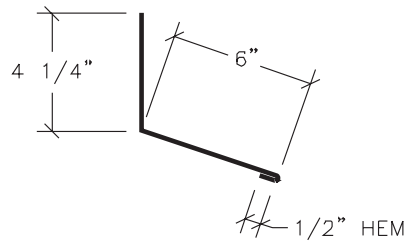

Endwall (EW6)

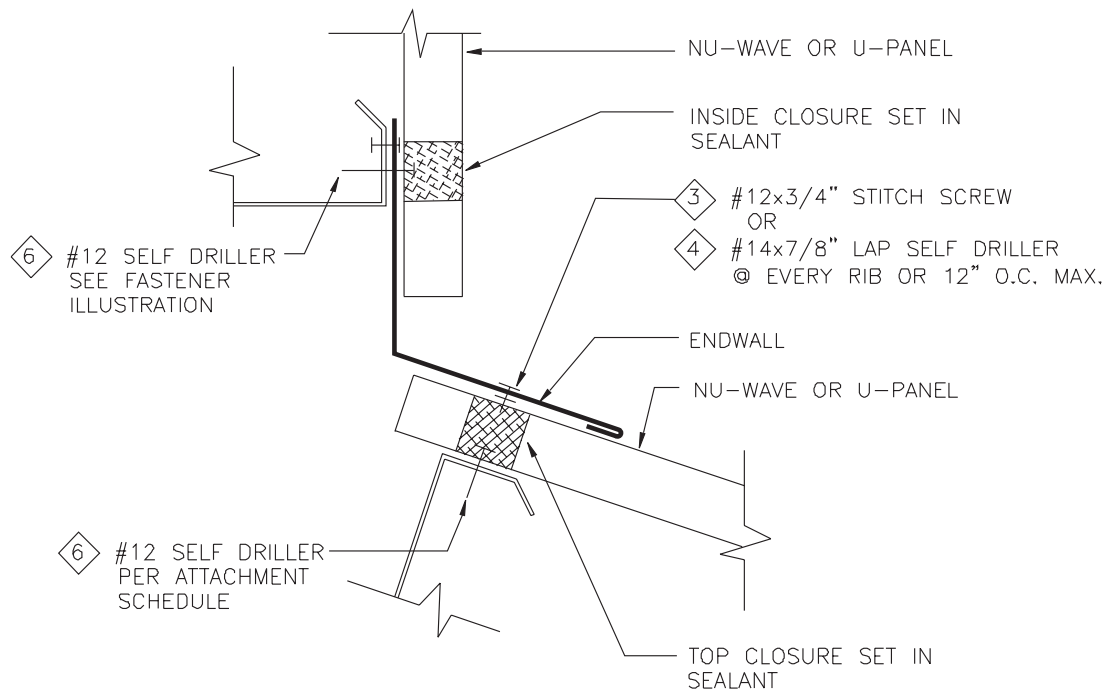

Wall Details • Base Trim

NuWave Corrugated & U-Panel

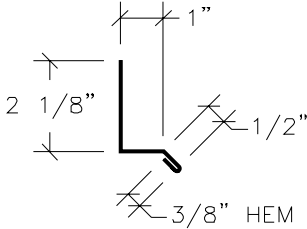

Base Trim (B1)

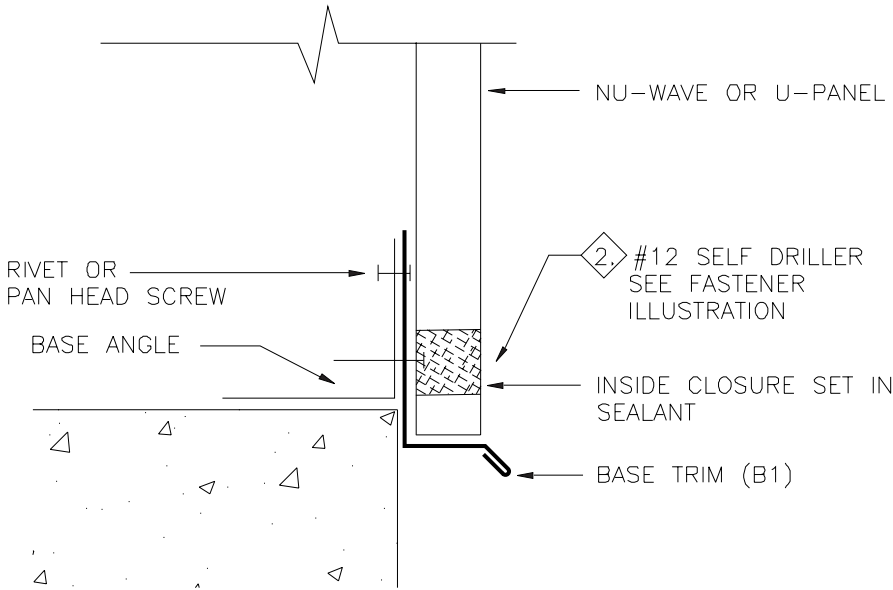

Wall Details • “C” Trim

NuWave Corrugated & U-Panel

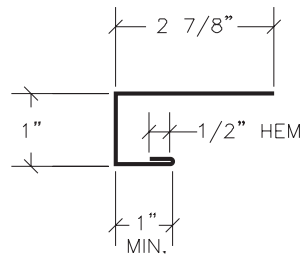

“C” Trim (C13)

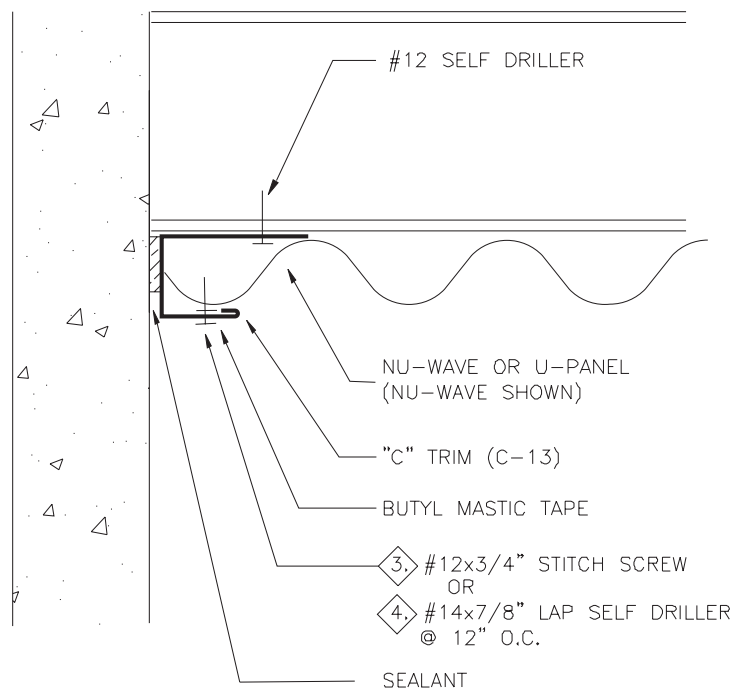

Wall Details • Inside Corner

NuWave Corrugated & U-Panel

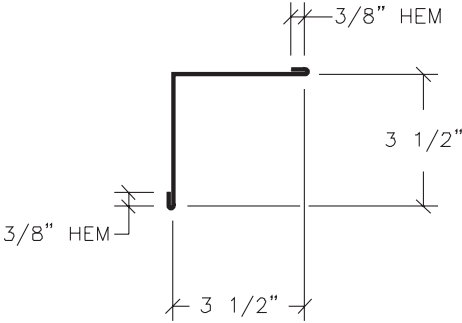

Inside Corner (IC2)

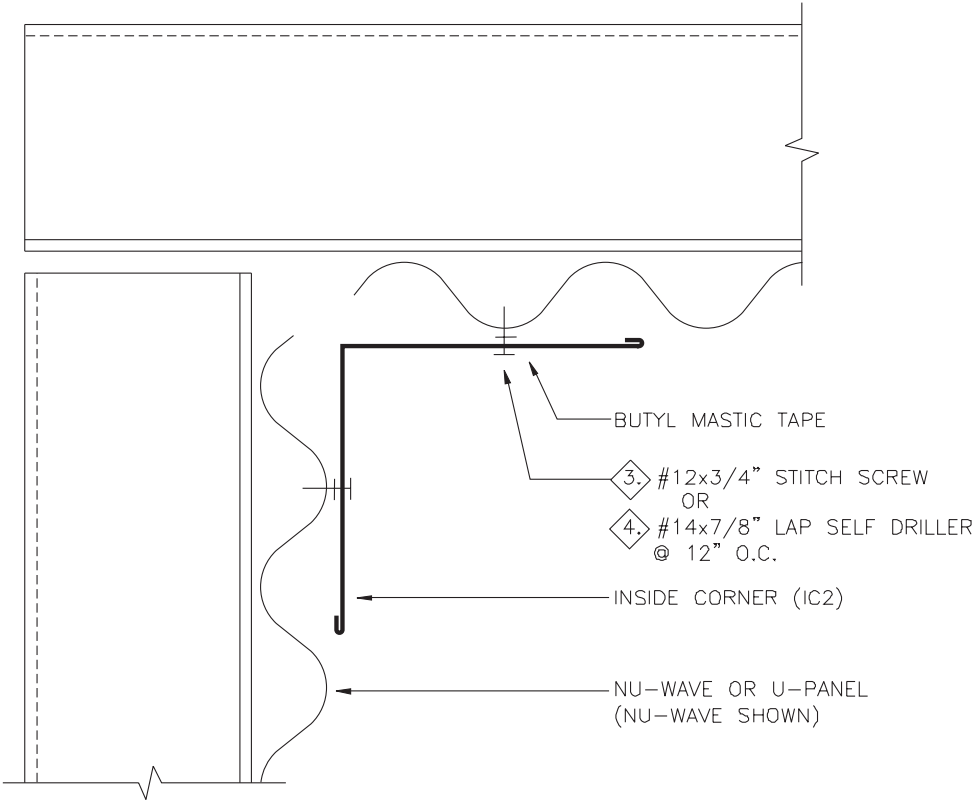

Wall Details • Outside Corner

NuWave Corrugated & U-Panel

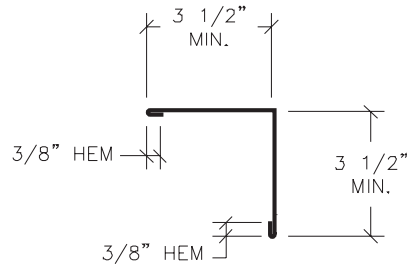

Outside Corner (OC2)

