

# U-Panel

Featuring

**Zincalume® For Twice the Life!**

Zincalume combines the strength of steel with the corrosion resistance of aluminum for twice the life of most zinc coatings.

**U-Panel** is a “Utility” panel known for its economical through-fastened design preferred for light commercial and industrial roof or wall applications. U-Panel is especially suitable as an interior partition or liner panel for mini-storages.

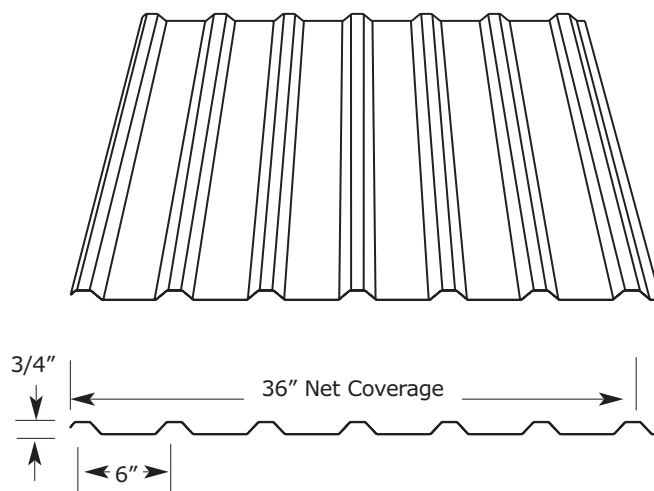

## features | benefits

- Structural spanning allows panel to be installed over solid substrates or spaced support members.
- Full-bearing sidelap rib provides consistent weather-resistant joint.
- Manufactured with high tensile steel for greater load capability.
- Matching trim packages are available in the same gauge and color as the roof panel.
- Can be installed on pitches as low as 3:12.
- 24 gauge can be crimp curved to accommodate rADIUS applications.
- Matching trim packages are readily available.
- 26 gauge U-Panel available in a wide variety of standard “Cool” colors with the DuraTech®nt coating system.
- 24 gauge U-Panel is offered in Zincalume® Plus for unpainted applications as well as “Cool” Surf White in the DuraTech®nt coating system.
- 29 gauge U-Panel is offered in the corrosion resistant Zincalume® Plus for unpainted applications.

U-Panel Section Properties

Gauge	Wt. (lbs/ft²)	S+ (in³/ft)	I+ (in⁴/ft)	S- (in³/ft)	I- (in⁴/ft)
29	0.68	0.0294	0.0170	0.0260	0.0117
26	0.89	0.0436	0.0243	0.0382	0.0163
24	1.13	0.0592	0.0323	0.0538	0.0220

