

Box Rib™ Wall

Commercial and Industrial Wall Application
26 & 29 gauge

Featuring

Zincalume® For Twice the Life!

Zincalume combines the strength of steel with the corrosion resistance of aluminum for twice the life of most zinc coatings.

Box Rib is a through-fastened metal panel with 36" net coverage and is predominantly used for industrial and pre-engineered wall applications.

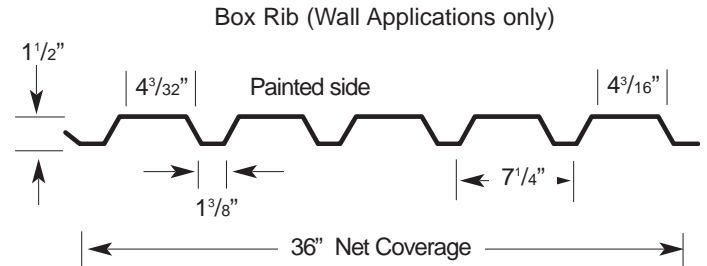
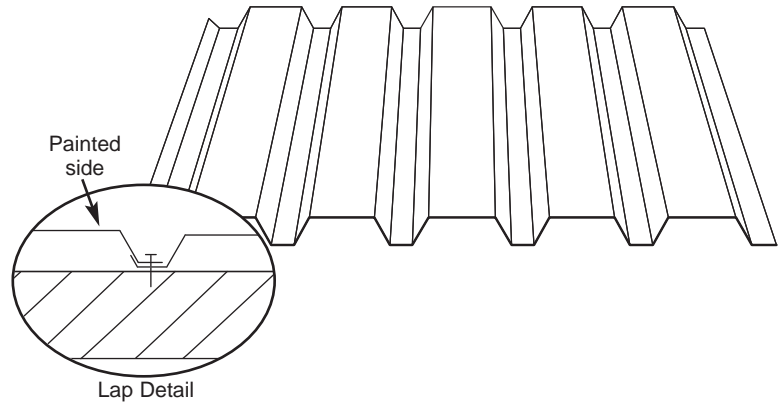

features | benefits

- Wider coverage means fewer panels to handle and install, saving time and money.
- Panel design provides superior load and span capacities which often allow savings in the structural support system.
- Quick, economical trim packages include standard trim pieces that can be ordered by number.
- High tensile steel panels in 26 gauge available with the DuraTech®nt coating or unpainted Zincalume® Plus.
- Exceptional value in high tensile steel 29 gauge panels coated with the ColorGuard™xt coating system. Choose from Surf White, Desert Beige, Lightstone or Zincalume® Plus for unpainted applications.
- Fiberglass panels available in matching profile.

Box Rib Section Properties

Gauge	Wt. (lbs/ft ²)	S+ (in ³ /ft)	I+ (in ⁴ /ft)	S- (in ³ /ft)	I- (in ⁴ /ft)
29	0.69	0.0367	0.0350	0.0376	0.0440
26	0.95	0.0661	0.0573	0.0646	0.0713



Tacoma, WA 800-733-4955, 253-383-4955, FAX 253-272-0791
 Fontana, CA 800-272-2466, 909-823-0401, FAX 909-823-2625
 Dallas, TX 800-527-2503, 214-827-1740, FAX 214-828-1394
 Kernersville, NC 800-527-2503, 214-827-1740, FAX 214-828-1394

www.aepspan.com